

LOW VOLTAGE IGNITION SYSTEM 30DC

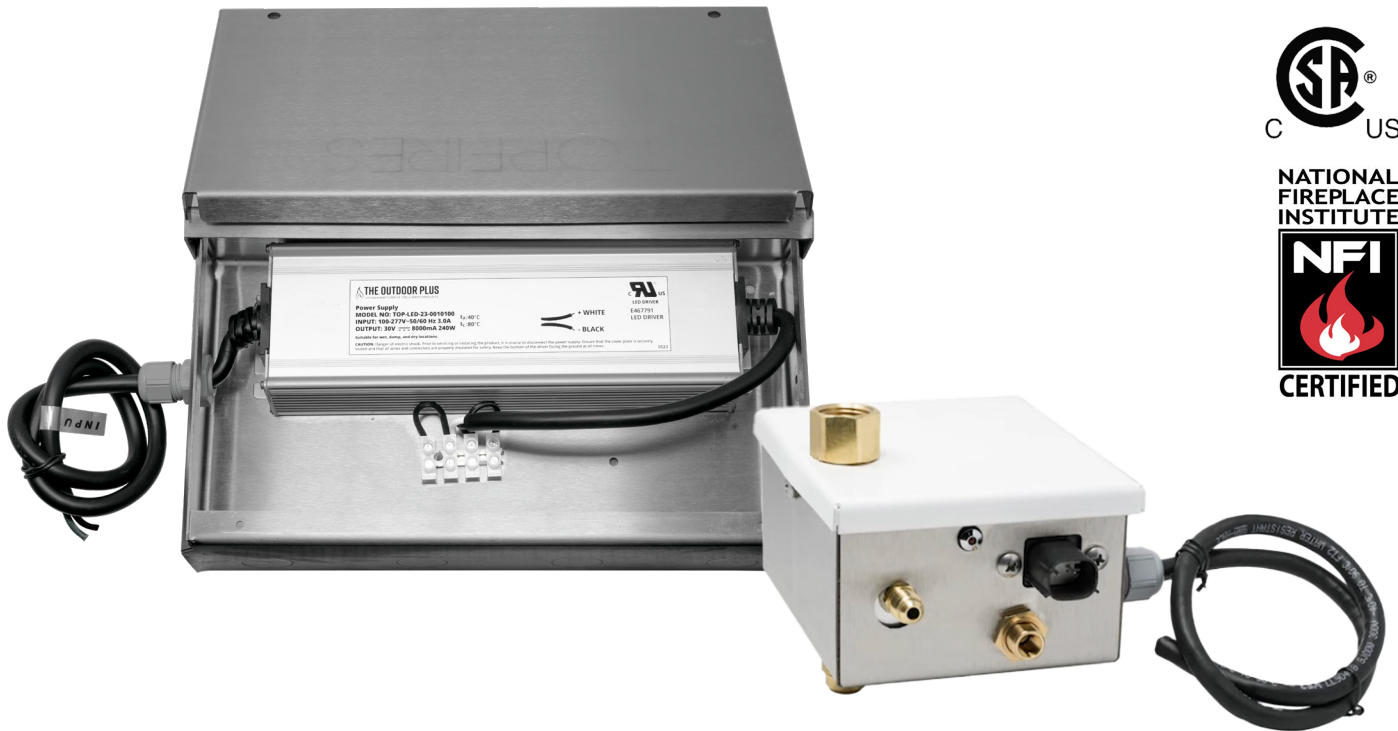

NATIONAL
FIREPLACE
INSTITUTE



INSTALLATION & OPERATION MANUAL

TO INSTALLER: Leave this manual with the appliance.
TO CONSUMER: Keep this manual for future reference.



WARNING

Do NOT store or use gasoline or other flammable liquids or vapors in the vicinity of this or any other appliance. An LP cylinder not connected for use shall not be stored in the vicinity of this or any other appliance. For use with Natural or Propane gas only.



THIS IS A SAFETY ALERT SYMBOL

When you see this symbol on the fire feature or manual, look for one of the following signal word panels alerting you to the potential for personal injury, death, or major property damage.

⚠ WARNING
 FOR OUTDOOR USE ONLY. Installation and service must be performed by a qualified installer, service agency, or the gas supplier.

⚠ CAUTION
 IMPROPER USE. Use this equipment only for its intended purpose. Misuse or modification of the equipment may result in injury or damage to the equipment.

⚠ DANGER
 FIRE OR EXPLOSION HAZARD. If you smell gas:

- Shut off gas to the appliance.
- Extinguish any open flame.
- Open lid.
- If odor continues, keep away from the appliance and immediately call your gas supplier or your fire department.

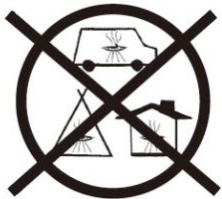

⚠ DANGER: CARBON MONOXIDE HAZARD
 This appliance can produce carbon monoxide which has no odor. Using it in an enclosed space can kill you.
 Never use this appliance in an enclosed space such as a camper, tent, car, or home.

⚠ WARNING
 FIRE HAZARD. Maintain a clean area around your Fire Feature, ensuring it is free from flammable liquids and other combustible materials like mops, rags, brooms, solvents, cleaning fluids, lighter fluid, and gasoline.

⚠ WARNING
 If the information in this manual is not followed exactly, a fire or explosion may result causing property damage, personal injury, or loss of life.

⚠ WARNING
 Do not install the Fire Feature on combustible material, or material that can obstruct ventilation such as wood, grass, loose sand, and loose gravel.

**WARNING**

FIRE OR EXPLOSION HAZARD. If you smell gas: Shut off gas to the appliance and extinguish any open flame. If odor continues, leave the area immediately. After leaving the area, call your gas supplier or Fire Department.

**WARNING**

Do not use lighter fluid in the Fire Feature. Product is not intended to be a starter for wood or any other combustibles. Always have a fire extinguisher nearby.

**WARNING**

NEVER leave the Fire Feature unattended. Keep children and pets away from the Fire Feature at all times.

**WARNING**

The Outdoor Plus suggests that our products be installed by professionals that are locally licensed by the authority having jurisdiction in gas piping. Our products should be serviced annually by a professional certified in the US by the National Fireplace Institute (NFI) as Gas Specialists or in Canada by WETT (Wood Energy Technical Training).

**WARNING**

The Outdoor Plus Company, Inc. is not responsible for your actions.

**WARNING**

Only use gas/fuel type specified for this fire pit. See label on the fire pit control box. Gas pressure and type should be checked prior to use and installation.

**WARNING**

Do not use this appliance if any part has been under water. Immediately call a qualified service technician to inspect the appliance and to replace any part of the control system and any gas control.

**WARNING**

It is the installer's responsibility to ensure a safe installation and to educate the end user as to proper operation.

**WARNING**

NOT SUITABLE FOR USE BY CHILDREN. Only adults who understand the proper operation and safety precautions for the Fire Feature should handle it.

**WARNING**

For the safety of yourself and others, ensure that the Transformer is plugged into a GFCI Outlet.

- Finding and/or fixing a gas leak is NOT a “DO-IT-YOURSELF” procedure - ONLY USE A PROFESSIONAL.
- NEVER USE THE FIRE FEATURE WITHOUT FIRST LEAK TESTING THE GAS CONNECTIONS INCLUDING ALL OF THE VALVES, FITTINGS, LINES ETC. (ALL GAS CONNECTIONS SHOULD BE CHECKED).
- WARNING: DO NOT USE OPEN FLAME TO CHECK FOR LEAKS. USE OF AN OPEN FLAME COULD RESULT IN A FIRE, EXPLOSION AND BODILY HARM.
- DO NOT SMOKE WHILE PERFORMING THE LEAK TEST. Any open flame will ignite the gas.
- Check to ensure that flexible hoses do not have any cuts and wear that may affect the safety before each use. Only the factory supplied hose and regulator must be used. Use only replacement regulator and hose assemblies specified by The Outdoor Plus.

CHECKING FOR GAS LEAKS:

Perform a leak test before each use. In addition, whenever the gas cylinder is connected to the regulator or whenever any part of the gas system is disconnected or replaced, perform a leak test. As a safety precaution, remember to always leak test your appliance outdoors in a well-ventilated area. Never smoke or permit sources of ignition in the area while doing a leak test. Do not use a flame, such as a lighted match to test for leaks. Use a solution of soapy water.

- Prepare a leak testing solution of soapy water by mixing in a spray bottle one part liquid soap to one part water.
- Make sure all the control knobs are in the OFF position.
- Turn on the gas:
 - On Natural Gas systems, turn the main feed valve to the appliance.
 - On LP systems, turn the cylinder valve knob counter clockwise one turn to open.
- Apply the leak-testing solution by spraying it on joints of the gas delivery system. This includes all valves, pipe connections, joints, lines, and every point from the gas source to the burners.
- Emerging bubbles in the soap solution or and/or if there is a faint gas smell (gas typically has an egg smell) indicates that a leak is present. Do not attempt to ignite the side burner.
- Turn all control knobs back to the full OFF position.

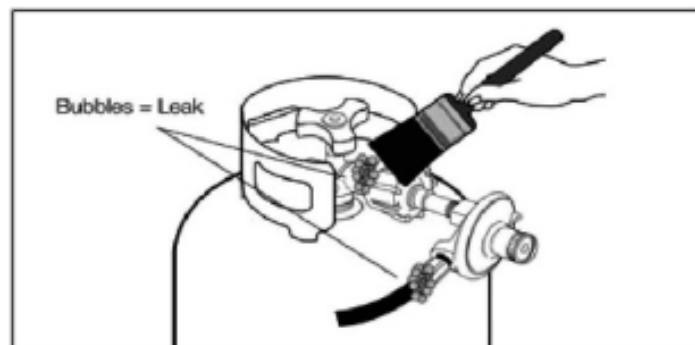

- All gas connections should be made by a Professional qualified technician and in accordance with local codes and Ordinances. The installation must conform with local codes or, in the absence of local codes, with either the national Fuel Gas Code, ANSI Z223.1/NFPA 54, or CAN/CGA-B149.1, Natural Gas Installation Code or CAN/CGA-B149.2, Propane Installation Code.
- The outdoor gas appliance and its individual shut-off valve must be disconnected from the gas supply piping system during any pressure testing of that system at test pressures in excess of 1/2 psi (3.5 kPa).
- The outdoor gas appliance must be isolated from the gas supply piping system by closing its individual manual shut-off valve during any pressure testing of the gas supply piping system at test pressures equal to or less than 1/2 psi (3.5 kPa).
- Check the rating label attached on the outside of the unit.
- Do not twist the gas supply hose.
- Before each use, visually inspect the gas supply hose for cracks, cuts or excessive wear. Replace the hose if necessary. Check for gas leaks before each use.
- Gas Specifications: A Natural Gas appliance requires natural gas to operate; an LP appliance requires liquid propane gas to operate.
- Never connect the appliance to an unregulated gas supply line. Appliances operated without a regulator are unsafe and will not be serviced until installed properly and safely. Unsafe operation without a gas regulator will void the warranty of the appliance.
- Appliances operated with NG (natural gas) must be installed with the NG regulator supplied with the unit and set to 4.0" water column pressure.
- Appliances operated with LP (liquid propane) gas must be installed with an LP regulator set to 11" water column pressure.
- Please contact your dealer and use a licensed contractor or installer to convert your appliance to the different gas type.
- CHECK TO ENSURE THAT THE GAS SUPPLY HOSE DOES NOT COME IN CONTACT WITH ANY HOT SURFACE, SHARP OR ROUGH EDGES. DO NOT KINK THE GAS LINE WHEN INSTALLING.

 **DANGER**

Flammable gas under pressure. Leaking LP-Gas may cause a fire or explosion if ignited causing serious bodily injury or death. Contact Gas Supplier for repairs, or disposal of this cylinder or unused LP-Gas.

 **WARNING**

For outdoor use only. Do not use or store cylinder in a building, garage, or inclosed area.

WARNING:

- Know the odor of LP-Gas. If you hear, see, or smell leaking LP-Gas, immediately get everyone away from the cylinder and call the Fire Department. Do not attempt repairs.
- Caution your LP-Gas supplier to:
 1. Be certain cylinder is purged of trapped air prior to first filling.
 2. Be certain not to over fill the cylinder.
 3. Be certain cylinder requalification date is checked.
- LP-Gas is heavier than air and may settle in low places while dissipating.
- Contact with the liquid contents of cylinder will cause freeze burns to the skin.
- Do not allow children to tamper or play with cylinder..
- When not connected for use, keep cylinder valve turned off. Self contained appliances shall be limited to a cylinder of 30lb capacity or less.
- Do not use, store, or transport cylinder where it would be exposed to high temperatures. Relief valve may open allowing a large amount of flammable gas to escape.
- When transporting, keep cylinder secured in an upright position with cylinder valve turned off.

WHEN CONNECTING FOR USE:

- Use only in compliance with applicable codes.
- Read and follow manufacturer's instructions.
- Consult manufacturer's instructions concerning the cylinder connection provided with your appliance.
- Be sure regulator vent is pointing up.
- Turn off all valves on the appliance.
- Do not check for gas leaks with a match or open flame. Apply soapy water at areas marked "X". Open cylinder valve. If bubble appears, close valve and have LP-Gas service person make needed repairs. Also, check appliance valves and connections to make sure they do not leak before lighting appliance.

- Light appliance(s) following manufacturer's instructions.
- When appliance is not in use, keep the cylinder valve closed.
- Do not store a spare LP cylinder under or near a barbecue grill or other heat sources. Never fill an LP cylinder beyond 80% full. A fire causing death or serious injury may occur.

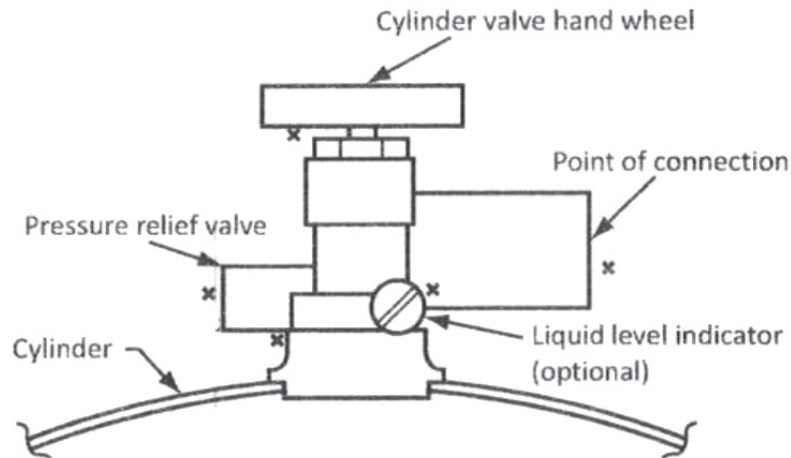

IT IS THE RESPONSIBILITY OF THE INSTALLER TO FOLLOW:

- The National Fuel Gas Code, ANSIZ 223.1 /NFPA 54, ANSI STD Z21.58,-2022 CSA STD 1.6-2022
- The National Electrical Code, ANSI/NFPA 70

SUPPLY PRESSURE

LIQUID PROPANE SUPPLY PRESSURE:

Minimum: 8" W.C. 1.99 kPa
Nominal: 11" W.C. 2.73 kPa
Maximum: 14" W.C. 3.48 kPa

NATURAL GAS SUPPLY PRESSURE:

Minimum: 3.5" W.C. .87 kPa
Nominal: 7" W.C. 1.74 kPa
Maximum: 14" W.C. 3.48 kPa

⚠ CALIFORNIA PROP 65 WARNING ⚠

This product can expose you to chemicals including Lead and Lead Compounds, which are known to the state of California to cause cancer, and Carbon Monoxide, Lead and Lead Compounds which are known to the state of California to cause birth defects or other reproductive harm. For more information go to www.P65Warnings.ca.gov.

SAFETY

WARNING LABELS & SAFETY	2
GAS SAFETY	4
TABLE OF CONTENTS	8

DC IGNITION SYSTEM INFORMATION

COMPONENTS OVERVIEW	9
OPERATION SEQUENCE	11
SELECTING THE LOCATION	12
ENCLOSURE CONSTRUCTION	13

DC IGNITION SYSTEM INSTALLATION

PRE-PLANNING CHECKLIST	15
INSTALLATION INSTRUCTIONS	16
FIRE MEDIA USAGE	24
PARTS LIST	26

DC IGNITION SYSTEM PERFORMANCE

OPERATION & USAGE	27
TROUBLESHOOTING	31
CARE & MAINTENANCE	34
REPLACEMENT PARTS	36
CLEARANCE FROM COMBUSTIBLES	37

WARRANTY & SUPPORT

WARRANTY INFORMATION	38
CUSTOMER SUPPORT	40

COMPONENTS OVERVIEW

- Installation must conform with local codes or in absence of local codes, with the National Fuel Code, ANSI Z223.1 / NFPA 54, or International Fuel Gas Code.
- The appliance when installed, must be electrically grounded in accordance with local codes, or in the absence of local codes, with the National Electrical Code, ANSI / NFPA 70, or the Canadian Electrical Code, CSA C22.1 if applicable.
- When an appliance is connected to a fixed piped system, the installation must conform with local codes, or in the absence of local codes with the National Fuel Gas Code, ANSI Z223.1 / NFPA 54, National Fuel Gas Code, Natural Gas and Propane Installation Code, CSA B149.1, or Propane Storage and Handling Code, CSA B149.2, as applicable.

COMPONENTS OVERVIEW

- Certified to ANSI Z21.97 - (2017) / CSA 2.41 - (2017)
- -20° to 175° temperature range.
- Durable connections designed to resist outdoor conditions.
- LED diagnostics.

ELECTRONICS

- Electronics are certified for CAN/CSA-E60730-1, ANSI Z21.20 - 2014, CAN/CSA - C22.22 No.60730-2-5-14, UL 60730-2-5 Edition 3, & UL 60730-1.
- Transformer to GFCI Outlet connection for safety.
- Potted control module to protect against moisture and damage.
- Thermocouple Flame Sense, fast responding and resistant to wind, moisture, and corrosion.
- LED diagnostics for field service and troubleshooting.

GAS VALVE AND PILOT COMPONENTS

- The manual key valve is CSA Certified to ANSI Z21.15/CSA9.1.
- The pilot is CSA Certified to ANSI Z21.20.
- Coils are encapsulated to protect against moisture.
- Pilot has robust flame pattern, wind resistant.
- Pilot injectors are stainless steel.
- Thermocouple is nickel plated for durability.
- The Power Wire connector is waterproof.

GAS CONNECTION

- Installation or repair should be performed by a qualified service technician who is locally licensed. The appliance should be inspected before use and at least annually by a qualified technician.
- Do NOT remove any decal/rating plates from the Electronic Ignition Valve. A gas shut off must be installed outside the exterior of the fire feature for emergency shut off and maintenance. A sediment trap is highly recommended to alleviate any problems from debris or sediment in the gas line. It is the installers responsibility to ensure the fuel supply and line are adequate to supply the maximum BTU for the burner used.
- **NOTE:** A heat shield/plate **MUST** be installed between the Electronic Ignition Valve and the burner ring to avoid over heating.
- The Electronic Ignition Valve box is pre-mounted to the burner or burner & pan combination.
- The Electronic Ignition Valve is designed to automatically close the gas valve and shut down should temperatures exceed 175° Fahrenheit. To keep the unit cool, proper ventilation and a heat shield must be provided.
- The Outdoor Plus Recommends a Stainless Steel Whistle-Free Flex Hose to eliminate the noise

PILOT ASSEMBLY CONNECTIONS

We pre-assemble the pilot on top of the burner pan and in that configuration, the pilot line, thermocouple, and igniter lead should be lowered through a hole in the pan prior to connecting to the control box. The pilot comes pre-assembled from the factory, so the installer can simply connect the assembly to the main control box. The igniter has a “shaped” push on waterproof connector ensuring that it can only be connected the correct way. Push the black plastic connector parts firmly together until it locks in place. Gently tug on wires to assure connection is secure. The flexible corrugated pilot tube has a flare fitting that should be connected 1/4 turn past hand tight. Please double check to ensure the fitting is snug both into the control box and the flare connection. The thermocouple should now be connected. It screws onto the 11/32” brass fitting on the control box closest to the black connector. It should be snug, but do not over-tighten.

Next, you may mount the pilot to the burner pan. The shield is designed with perforated material which you can use to secure to the pan with self tapping screws. The installer can determine the best placement for the pilot depending on the burner configuration keeping the pilot within 1” from a burner port for quick ignition. Once all connections are complete, it is highly recommended to perform a leak test. Turn on the gas supply and using gas test solution or soapy water solution, spray the gas connections on the Electronic Ignition Valve including the pilot connector to ensure it is leak free.

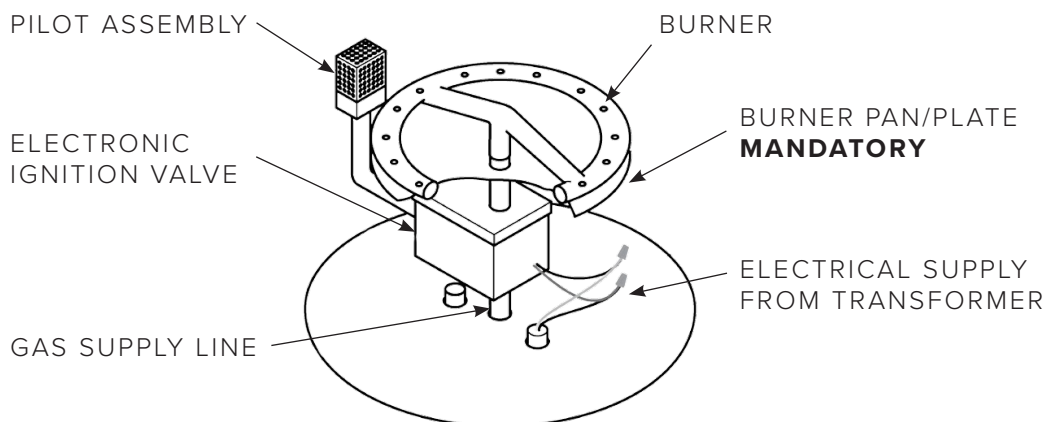

SEQUENCE OF OPERATION

• When activated, the unit initiates a pre-purge period upon detecting a call for heat. The hot surface ignitor (HSI) is energized for warm-up duration, followed by activation of the pilot gas valve during the trial-for-ignition period. Once ignition is achieved, the HSI deactivates. If flame detection occurs before the trial-for-ignition period elapses, the HSI deactivates. The main valve opens, and the pilot valve remains active until power is cut or flame signal is lost. In case of flame loss, the control shuts off the gas valve, initiating a flame loss recycle delay before restarting the ignition sequence. If no flame is detected during the trial-for-ignition period and trials-for-ignition remain, both the pilot and HSI deactivate, entering an inter-purge period before the next ignition attempt. If flame detection occurs before the gas valve activates, the control halts the sequence and enters safety shut-down until the flame drops below the minimum threshold or continuously drops by the minimum threshold value before proceeding.

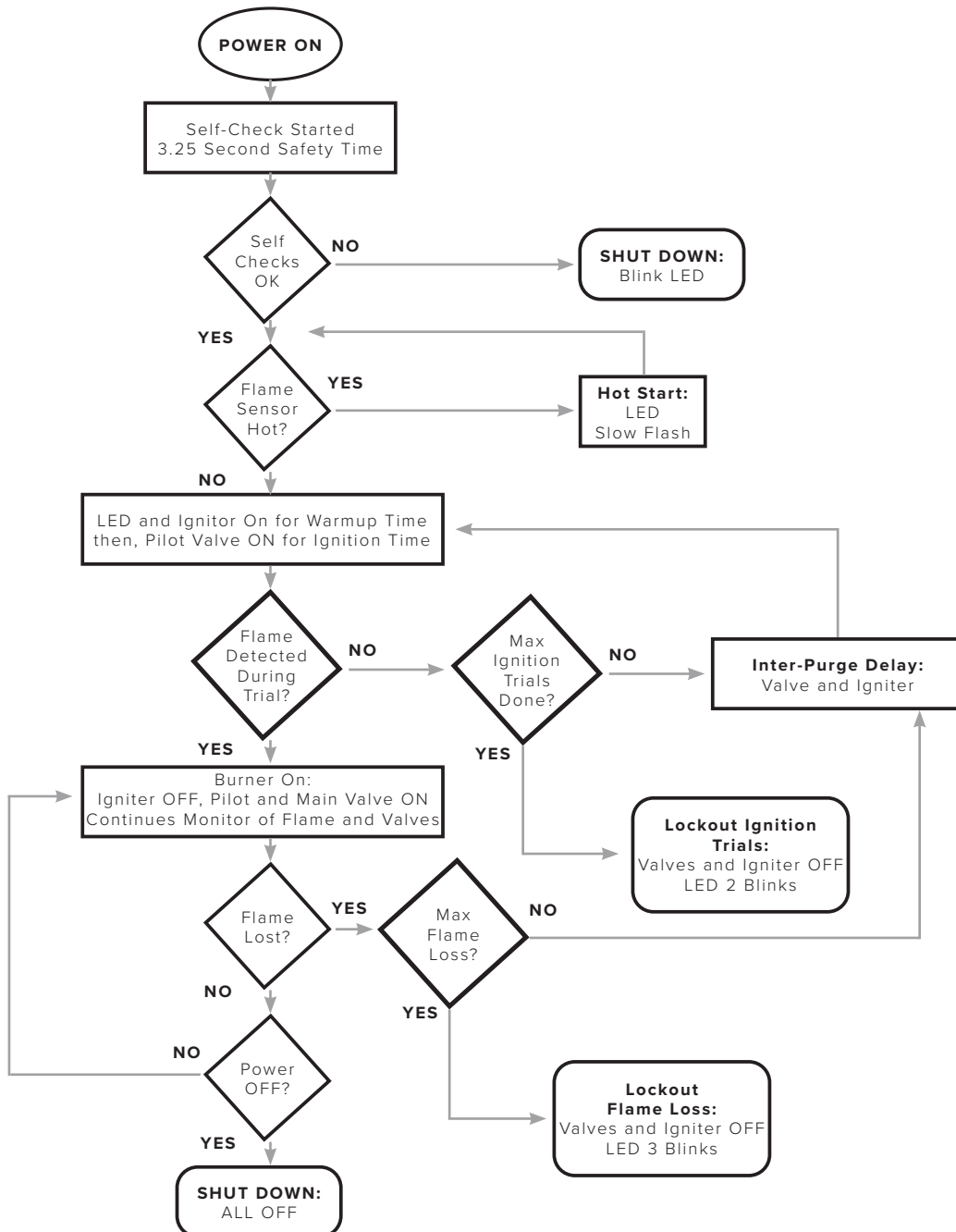

SELECTING THE LOCATION

WARNING:

- All fire pits, match lit kits, spark ignition, safety pilot and Electronic Ignition Components are designed and intended for outdoor use only.
- All fire pits must have a gas shutoff on the outside of the exterior of the fire pit to allow for emergency shut off and maintenance. **DO NOT PLACE ON TOP OF COMBUSTIBLE FLOORING.**
- Select a location where the fire pit can be attended during operation. Never leave an operating fire pit unattended or by someone not familiar with its operation or emergency shut off locations.
- Both children and adults should be alerted to the hazards of high surface temperatures and should stay away to avoid burns and clothing ignition.
- Young children should be carefully supervised when they are in the area of the fire pit.
- Clothing or other flammable materials should not be placed on or near the fire pit.
- Fire pits create very high temperatures - combustibles must be located far enough away that there is no risk of ignition.
- It is recommended that material such as granite, marble or other dense stone be kept away from heat and especially flame due to risk of cracking. Manufacturer is not responsible for damage.

CLEARANCE FROM COMBUSTIBLES (SEE PAGE 37):

UP TO 65K BTUS

Under Valve Box When Applicable	2" For Drainage
Sides Surrounding Fire Pit	Min. 48" From Structure or Combustibles
Overhead Clearance	Min. 96" Overhead Clearance

UP TO 66K - 200K BTUS

Under Valve Box When Applicable	2" For Drainage
Sides Surrounding Fire Pit	Min. 48" From Structure or Combustibles
Overhead Clearance	Min. 96" Overhead Clearance

UP TO 201K - 400K BTUS

Under Valve Box When Applicable	2" For Drainage
Sides Surrounding Fire Pit	Min. 48" From Structure or Combustibles
Overhead Clearance	Min. 96" Overhead Clearance



WARNING

Venting is required to dissipate heat and any residual fuel. Failure to provide proper ventilation could result in overheating and or explosion.

WARNING:

- All fire pits must have a gas shutoff on the outside of the exterior of the fire pit to allow for emergency shut off and maintenance.
- Always use proper materials and construction for gas supply, power, and enclosure.
- The interior void space of the enclosure surrounding the valve box cannot be filled with any material (gravel, crushed rock, concrete, etc.). It is a requirement to have a minimum of 2" under the valve box for proper ventilation and drainage.
- Select materials that are non-combustible in both initial installations as well as over time.
- The fire pit assembly should be recessed a minimum of 2.25" from the top of the enclosure to protect flame from being blown out. Some areas may require more: 4-6" is not uncommon.

WARRANTY REQUIREMENT

- The enclosure must be constructed on a stable surface. The weight of the fire pit must be supported by the pan and not by any control/valve box. For Electronic Ignition Components the control/valve box must be above grade with adequate drainage to prevent water damage to the controls inside the box.

IMPORTANT:

- Make sure that the structure is level. We recommend the use of the installation collar (optional) that may be mortared into the surround.
- The Outdoor Plus recommends that the pan lip is recessed on trough (linear). The Outdoor Plus cannot guarantee the lip on all of our products will be perfectly flat and will not warp due to heat.
- Product must be accessible for service.

PROPER VENTING

- Certain fire pit enclosures may require extra ventilation depending on size, material or extended use.
- 1 Square Inch of ventilation is **REQUIRED** for every 25,000 BTUs. This is especially important for propane units, as propane gas is heavier than air and can pool in the bottom of an enclosure.

ENCLOSURE CONSTRUCTION FOR SELF-CONTAINED PROPANE GAS SUPPLY SYSTEMS

- An enclosure for a propane gas cylinder shall be ventilated by openings at both the upper and lower levels of the enclosure. This shall be accompanied by one of the following:
 - One side of the enclosure shall be completely open; or
 - For an enclosure having four sides, a top, and a bottom:
 1. At least two ventilation openings shall be provided in the sidewalls of the enclosure, located within 5 in (217 mm) of the top of the enclosure, equally sized, spaced at a minimum of 90 degrees (1.57 rad), and unobstructed. The opening(s) shall have a total free area of not less than 1 2lb (14.2 cm²kg) of stored fuel capacity;
 2. Ventilation opening(s) shall be provided at floor level of the enclosure and shall have a total free area of not less than ½ in²•lb {7.1 cm²• kg) of stored fuel capacity. If ventilation openings at floor level are in a sidewall, there shall be at least two openings. The bottom of the openings shall be 1 in (25.4 mm) or less from the floor level and the upper edge no more than 5 in (127 mm) above the floor level. The openings shall be equally sized, spaced at a minimum of 90 degrees (1.57 rad), and unobstructed;
 3. Every opening shall have minimum dimensions so as to permit the entrance of a 1/8 in (3.2 mm) diameter rod;
 4. Ventilation openings in sidewalls shall not communicate directly with other enclosures of the appliance.
- The cylinder valve shall be readily accessible for hand operation. A door on the enclosure to gain access to the cylinder valves is acceptable, provided it is non-locking, and can be opened without the use of tools. Designs using a cover to gain access to the cylinder and cylinder valve shall be provided with handles or equivalent at a minimum of 180 degrees apart to facilitate lifting of the cover.
- The enclosure for the propane gas cylinder shall isolate the cylinder from the burner compartment to provide:
 1. Shielding from radiation
 2. A flame barrier
 3. Protection from foreign material
- There shall be a minimum clearance of 2in (50.8 mm) between the floor of the non-disposable propane gas cylinder enclosure and the ground.
- The design of the appliance shall be such that:
 1. A non-disposable propane gas cylinder can be connected and disconnected
 2. Connections can be inspected and tested outside the cylinder enclosure
 3. Connections, which could be disturbed when installing the cylinder in the enclosure, can be leak tested inside the enclosure

PRE-PLANNING CHECKLIST

- To ensure Proper Installation, please use this pre-planning checklist:

RECOMMENDED TOOLS:

- General Plumbing Tools (Pipe Wrench, crescent Wrench, Pipe Cutter, etc.)
- Manometer (To test static & dynamic gas pressure)
- Voltmeter (To check voltage & amperage to unit)
- Gloves
- Mini-Butane Torch
- Cordless Drill
- Dielectric Grease or Silicone (For waterproofing wire nuts)
- Whistle-Free Stainless Steel Flex Gas Hoses (TOP **does not** recommend using the standard yellow corrugated flex gas hoses as those cause a loud persistent whistle sound to occur when using the fire feature)
- Ensure the location is free of combustibles
- Measure & record distances of gas piping & electrical conduit runs, these will be useful for calculating gas pressure and proper wiring. The distance and wire gauge DIRECTLY influences the performance of the Electrical Ignition Component.
- The Fire Feature is delivered on a pallet via freight and placed in front of your home. Please have a team of movers ready to help move the unit from the curbside/driveway to the desired location. ALWAYS inspect the pallet for damage or missing pieces, if there is damage or missing pieces please DO NOT sign for the pallet and call our support team immediately to help resolve any problems.
- All fire features require a hollow area underneath the pan for serviceability of the unit, DO NOT FILL the hollow basin with sand or any other media.
- Gas Risers should come up to a maximum height of 2” from the ground and use a 90-degree fitting to help reduce the basin height and allow for easy servicing.
- TOP **DOES NOT RECOMMEND** to use the standard yellow corrugated gas flex hoses with its fire features. TOP recommends to use a Whistle-Free Steel Gas Flex Hose in order to help eliminate any whistling sounds.
- Ensure you use the Home-Run method for connecting multiple Electronic Ignition Component units. **DO NOT DAISY CHAIN** these units.
- Ensure you ordered the right gas type and ignition type for your installation.

STEP 1: SELECTING A LOCATION

- Please see Page 12 on selecting a location for instructions.

STEP 2: VENTILATION & ENCLOSURE CONSTRUCTION

- Please see Page 13 on ventilation and enclosure construction instructions.
- Confirm mounting brackets are used with bowls (mortared bowls will prevent proper venting and will cause electronics to prematurely quit working).
- Ensure lava rock media is not overfilled and does NOT cover the pilot for electronic systems.

STEP 3: GAS CONNECTION

- Please see Page 4 for warnings.
- Place a ball valve close to the gas piping coming from the building for safety purposes.
- Gas Flow Pressure Requirements | See Figure 1 on Page 18.
 1. Please reference Figure 1 on the next page - We are looking for 7" (Natural Gas) or 11" (Propane) Dynamic for optimum flow.
 2. Check dynamic & static gas flow pressure before the Electronic Valve Box with supplied Flared Fitting. See Figure 2 for a visual reference. For all units, please test static & dynamic gas pressure from gas riser.
 3. Flared Fitting goes in between the gas riser and the electronic valve box. Use the provided hoses to connect, ensure all gas fittings are tightly secured to prevent to gas leakage.
- If the unit has a manifold please See Figure 6, allow space in your design for at minimum 10 inch height basin for the manifold.
- For appliances for use with a fixed fuel piping system and equipped with an appliance gas pressure regulator, the appliance and its individual shutoff valve must be disconnected from the gas supply piping system during any pressure testing of the system at test pressures in excess of ½ psi (3.5kPa).
- The appliance must be isolated from the gas supply piping system by closing its individual manual shutoff valve(s) during any pressure testing of the gas supply piping system at the pressures equal to or less that ½ psi (3.5 kPa).

STEP 4: IGNITION OPTIONS

- There are numerous options available to turn on/off your fire feature, you may hard wire the provided transformer to a UL certified light switch, pool controller, smart home hub, wireless remote light switch, etc.
- Please See Figure 4 on Page 19 for a visual reference on the ignition options.



WARNING

Do not install the Fire Feature on combustible material, or material that can obstruct ventilation such as wood, grass, loose sand, and loose gravel.

STEP 5: ELECTRICAL CONNECTION & TESTING

- Place the transformer closer to the fire features (at minimum 5ft away from water & 1ft above ground on a wall). DO NOT CONNECT 110V DIRECTLY TO THE LOW VOLTAGE VALVE BOX.
- Check for incoming (110V) and outgoing voltage (30V DC). **See Page 23 for Transformer Chart & Guidelines.**
- Confirm that the appropriate wire gauge is being used. Test first with your supplied transformer **(See Figure 3)**.
- Confirm that a **240W** transformer is being used, the provided transformer can power up to **2** Low Voltage Pan & Burner units.
- The Low Voltage Ignition System has two white power wires. They're not polarity specific.
- Confirm that the appropriate voltage and amps are being used.
- The Transformer must be connected to a GFCI Outlet for safety.

STEP 6: APPLYING FIRE MEDIA

- Please see Page 24 on Fire Media Usage.
- **WARNING:** Media (Lava Rock or Fire Glass) must be a minimum of 1/4" and no larger than 3" in diameter.
For Natural Gas: You can use Fire Glass media or Lava Rock ranging from 1/4" to 3" in diameter.
For Liquid Propane: Avoid using glass pieces that are 1/2" in size or smaller. Opt for burning media between 1/2" and 3/4" - 1" in size, or larger.

STEP 7: OPERATION INSTRUCTIONS

- Please see Page 27 on Operation Instructions, this section outlines how to operate your Low Voltage fire feature.

FIGURE 1

GAS PRESSURE REQUIREMENTS

Ensure that the gas pressure is regulated according to The Outdoor Plus specifications.

Pressure	Gas Type	
	Natural Gas	Propane
Minimum	3.5" W.C. / 1/8 PSI / .87 kPa	8" W.C. / 1/3 PSI / 1.99 kPa
Nominal	7" W.C. / 1/4 PSI / 1.74 kPa	11" W.C. / 1/3 PSI / 2.73 kPa
Maximum	14" W.C. / 1/2 PSI / 3.48 kPa	14" W.C. / 1/2 PSI / 3.48 kPa

FIGURE 2

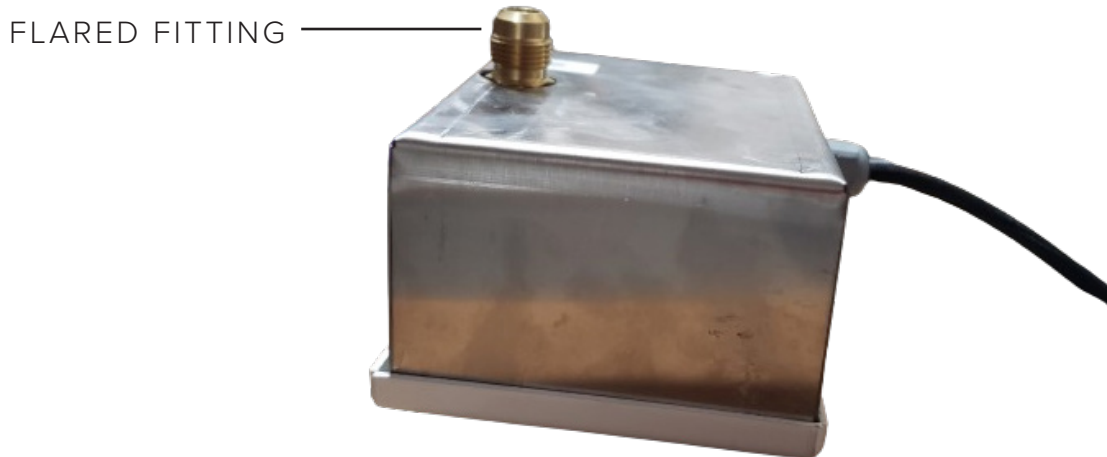

FIGURE 3

WIRE GAUGE CHART

Use the Wire Gauge Chart to the corresponding distance to ensure optimal performance for your ignition system.

Electrical Wire	6AWG	8AWG	10AWG	12AWG
Distance	5 FT	5 FT	5 FT	5 FT
	10 FT	10 FT	10 FT	10 FT
	20 FT	20 FT	20 FT	20 FT
	30 FT	30 FT	30 FT	30 FT
	40 FT	40 FT	40 FT	
	50 FT	50 FT	50 FT	
	60 FT	60 FT		
	70 FT	70 FT		
	80 FT	80 FT		
	90 FT			
	100 FT			
	110 FT			

FIGURE 4

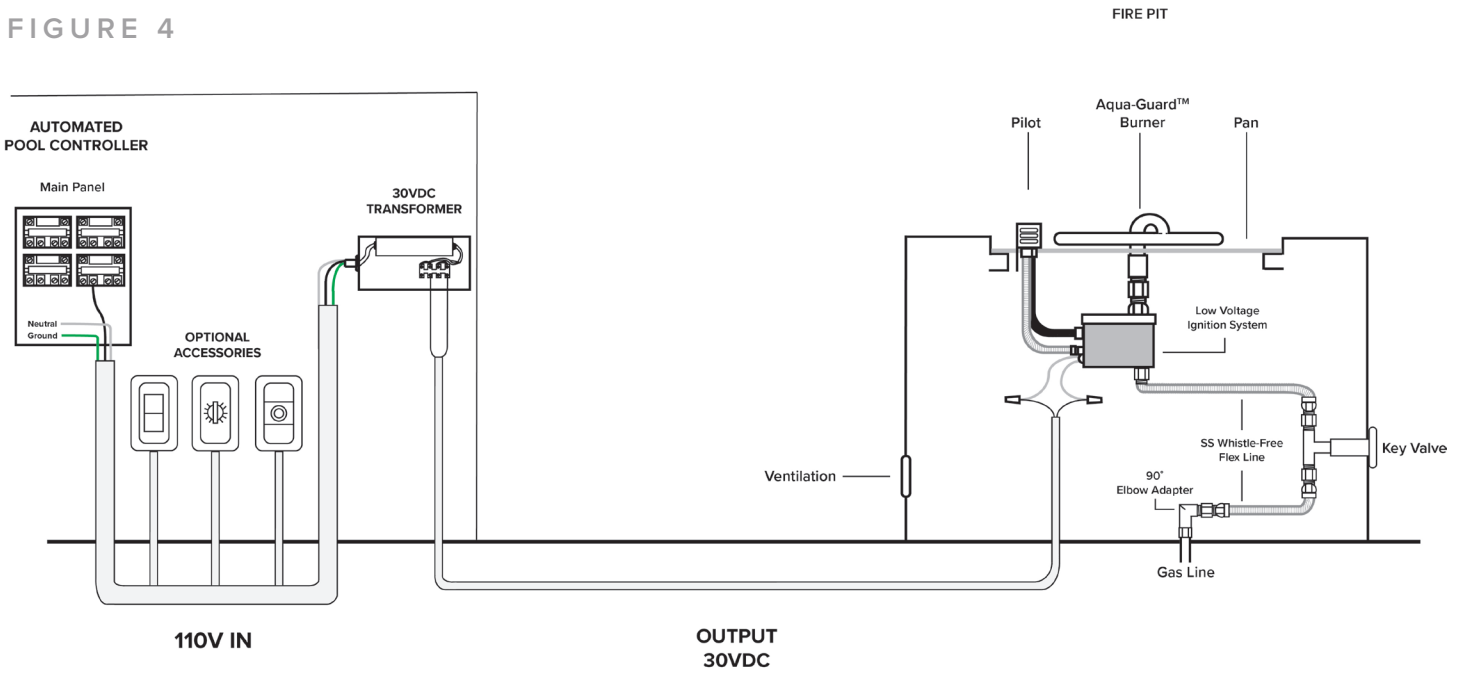

FIGURE 5

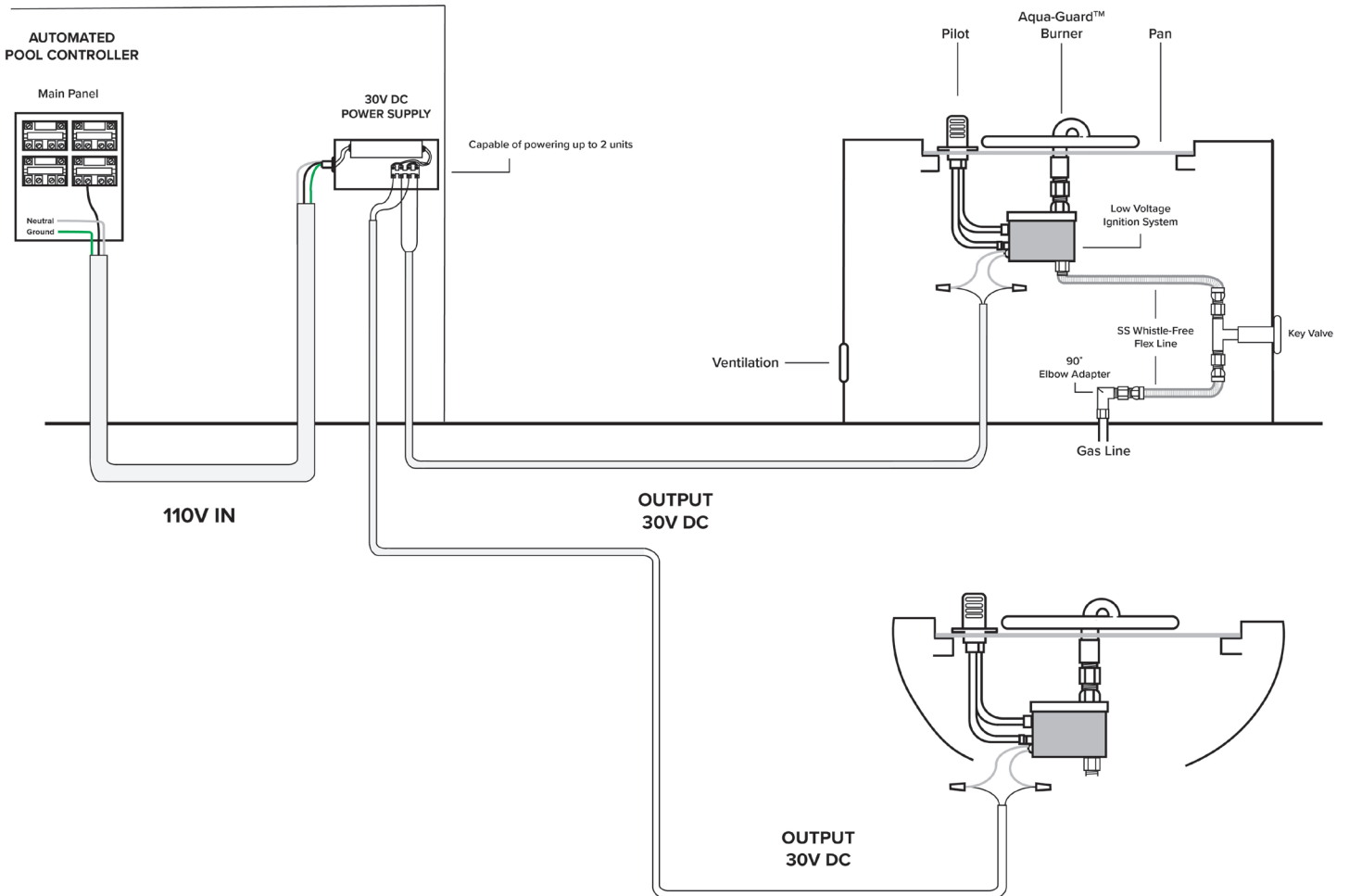
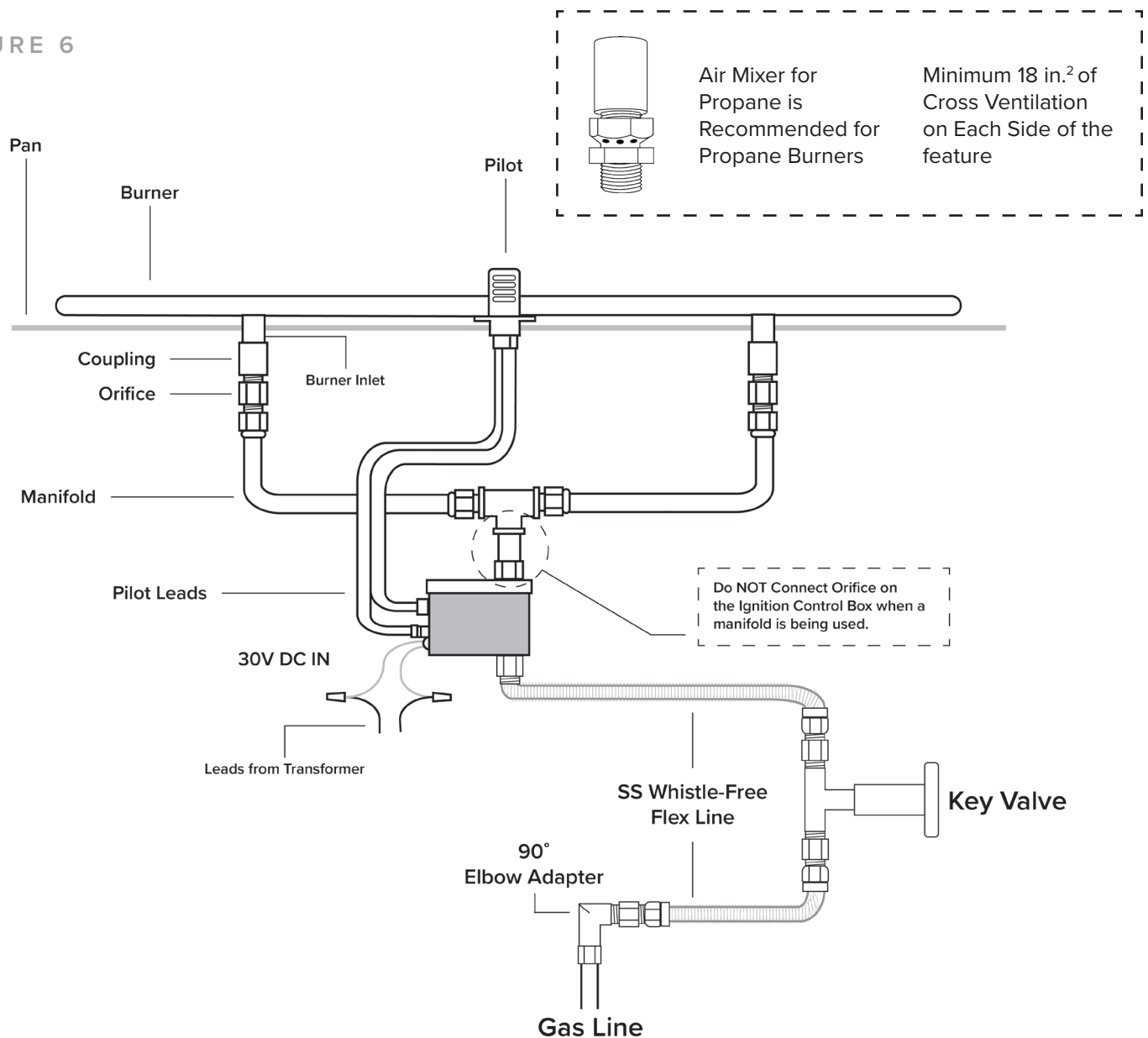

FIGURE 6



WARNING:

Failure to position the parts in accordance with these diagrams or failure to use parts specifically approved with this appliance may result in property damage or personal injury.

For Propane Installations:

1. Cross Ventilation is REQUIRED! A minimum of 1 square inch of ventilation is required for every 25,000 BTUs on each side of installation.
2. Propane tank must be placed in/on a propane tank retainer/non-tip base to ensure the propane tank will not tip over.
3. NOTE: Propane cylinder NOT included. Make sure to properly locate the gas hose including locating the hose out of pathways where people may trip over it or in areas where the hose may be subject to accidental damage.

NOTE:

If you are using a remote propane gas supply system please see the following two diagrams. For internal storage requirements, see Page 14.

Propane Cylinder NOT included. Please ensure the gas hose is correctly positioned to avoid tripping hazards and accidental damage.

FIGURE 7

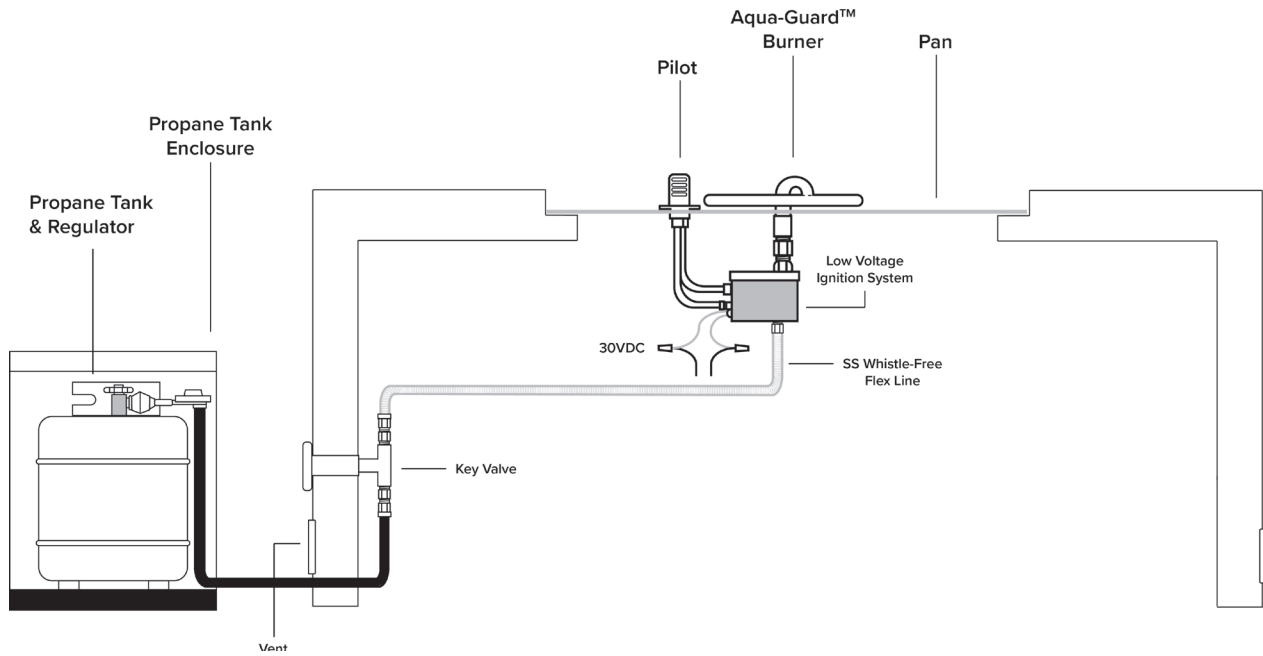
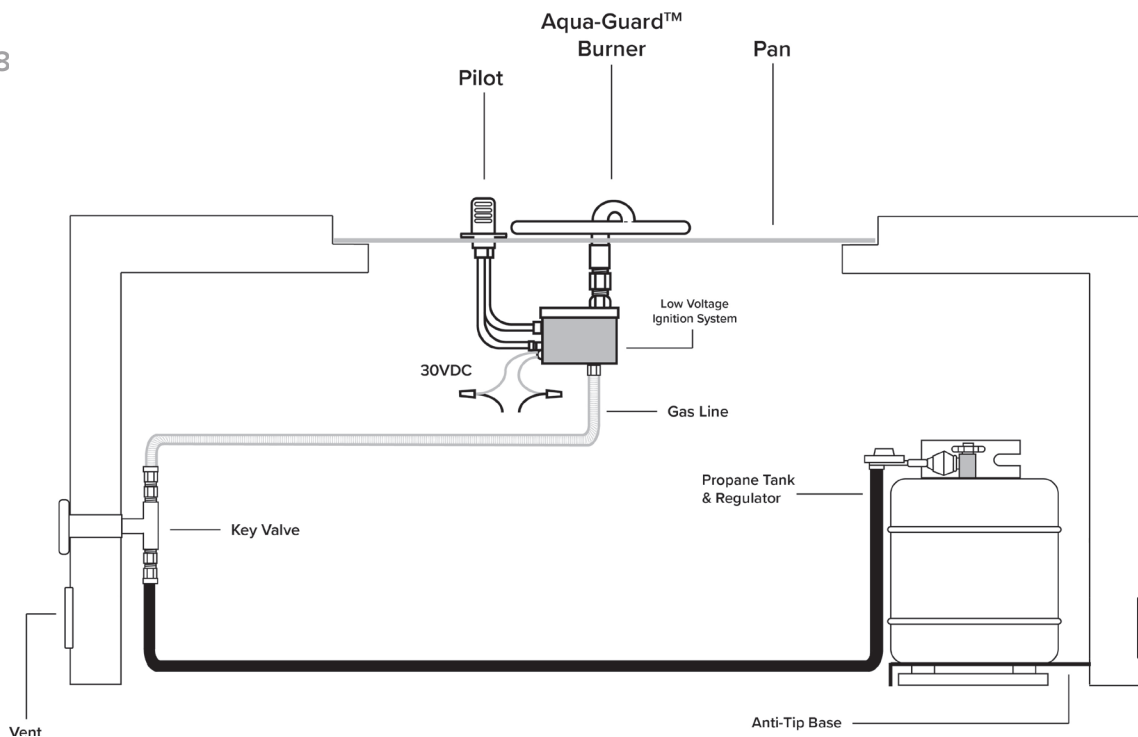

FIGURE 8



INSTALLATION INSTRUCTIONS

WARNING - RISK OF FIRE OR ELECTRICAL SHOCK:

- Do NOT submerge transformer.
- Do NOT connect two or more transformers in parallel.
- Do NOT use with dimmers.
- This Transformer must be installed according to the National Electrical Code (NEC) and local code requirements (For US installations article 680 and for Canadian installations, section 68 of the CEC). Important: This installation must be installed by a qualified electrician and is subject to approval by the local inspection authority.
- Use Copper Conductors only.
- Do NOT exceed the maximum ratings of individual components, wiring devices and current carrying capacity of conductors.
- Do NOT install this equipment within 5 feet (3 meters) of water.
- May be used with certified no-niche submersible luminaires or equivalent.
- Not for use with self-contained spas or hot tubs.
- For Canadian installation, supply circuit must be protected by a ground fault circuit interrupter.

GENERAL INFORMATION

- These Safety Transformers are specifically designed to supply 12 volts to pool/spa lights, submersible fixtures, and outdoor garden lights. The built-in circuit protection will disconnect power to the transformer in case of defect or overload. These transformers are suitable for direct connection to underwater Pool and Spa lights.
- Total of 4 knockouts located on the bottom of the transformer panel.
- Mount the transformer panel at least 1FT (30 cm) above ground.

WIRE GAUGE CHART

Use the Wire Gauge Chart to the corresponding distance to ensure optimal performance for your ignition system.

Electrical Wire	6AWG	8AWG	10AWG	12AWG
Distance	5 FT	5 FT	5 FT	5 FT
	10 FT	10 FT	10 FT	10 FT
	20 FT	20 FT	20 FT	20 FT
	30 FT	30 FT	30 FT	30 FT
	40 FT	40 FT	40 FT	
	50 FT	50 FT	50 FT	
	60 FT	60 FT		
	70 FT	70 FT		
	80 FT	80 FT		
	90 FT			
	100 FT			
	110 FT			

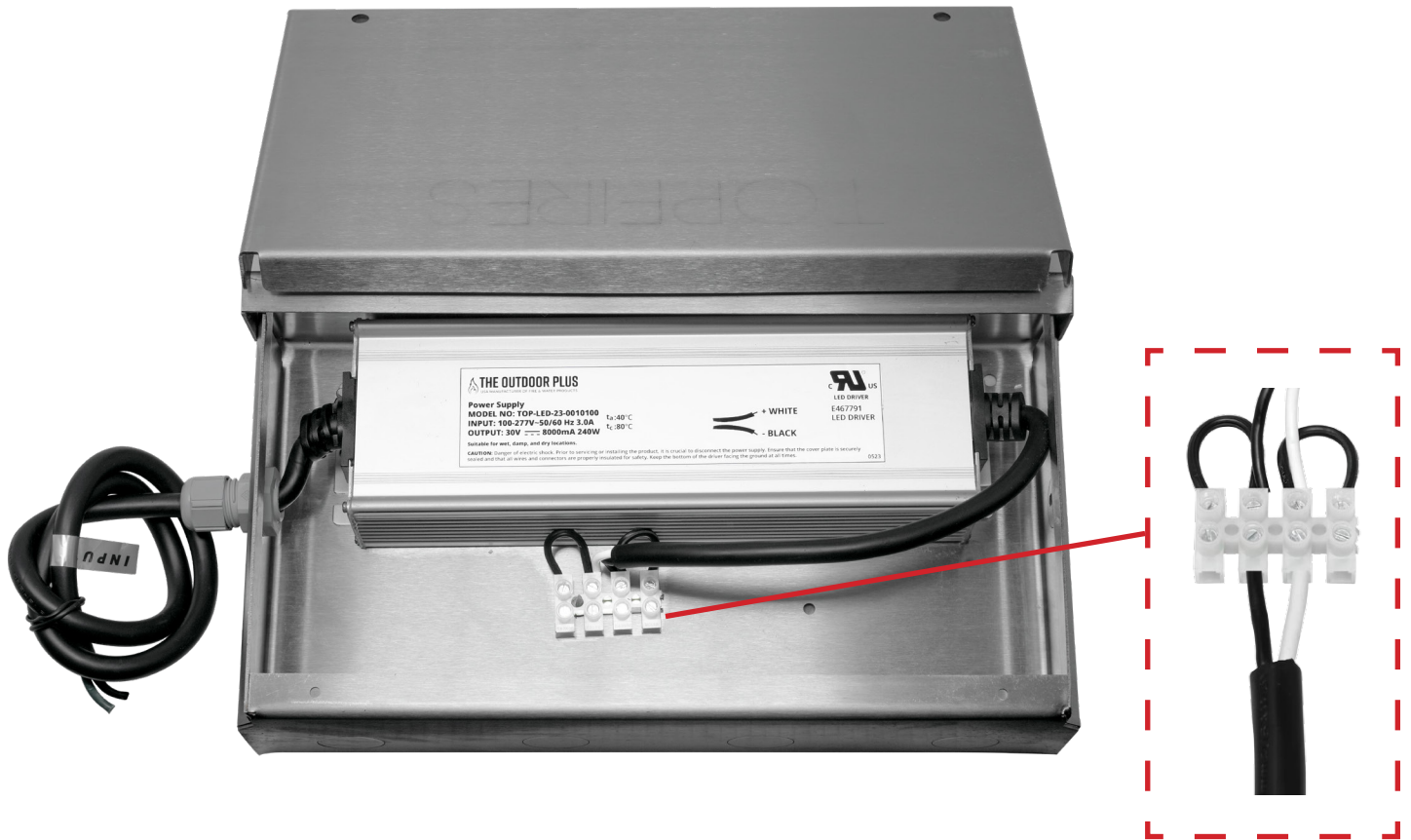

SPECIFICATIONS

Input	100-277V ~ 50/60Hz 3.0A
Output	30V $\overline{\text{---}}$ 8000mA 240W

INSTALLATION

- Make sure that all unused taps (leads) are separately insulated.
 - Use the following tables as a guide to determine the correct wire size.
 - The voltage at lamp terminals after installation should be 30 ± 0.3 VDC.
 - Voltages above 12.3V at the unit may cause the internal safety fuse of the transformer to switch off and on. To prevent this from happening, follow the **Wire Gauge Chart** on Page 22 and Page 30.
1. Select power source by combining Bulb wattage.
 2. Determine length of cable run(s).
 3. Determine wire gauge needed to deliver necessary power.
 4. Connect cable to output tap of transformer given in table.

NOTE: The Transformer must be connected to a GFCI Outlet for safety.



WARNING

Media (Lava Rock or Fire Glass) must be a minimum of 1/4" and no larger than 3" in diameter.

For Natural Gas: You can use Fire Glass media or Lava Rock ranging from 1/4" to 3" in diameter.

For Liquid Propane: Avoid using glass pieces that are 1/2" in size or smaller. Opt for burning media between 1/2" and 3/4" - 1" in size, or larger.

- Media used in the fire feature enhances the look of the flame and improves the fire pit performance. As gas is emitted from the burner, the media helps mix air with fuel resulting in a more uniform flame and a cleaner burn. The media will also spread the flame across all areas of the burner resulting in faster and more even ignitions.
- The media covering the burner should never exceed 3." With all media, the pilot burner **MUST** be left open to the air for proper ignition. When the media is placed correctly, you should see the top of the pilot burner shield. If ignition is delayed or inconsistent, you may need to remove some media from the pilot burner area. When using propane gas it is important to check for back pressure created by excessive use of media that could result in gas being forced back through the air mixer.



WARNING

If the information in this manual is not followed exactly, a fire or explosion may result causing property damage, personal injury, or loss of life.



WARNING

Placement of media must **NOT** cover the pilot assembly. Do not use sand or small media.

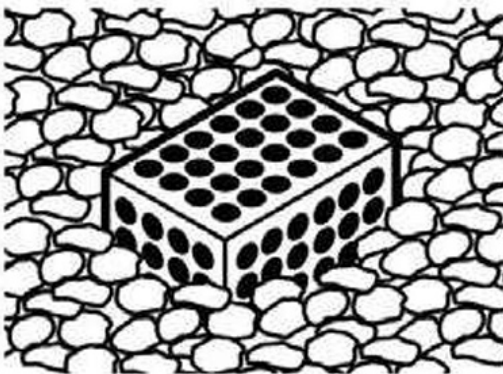

PILOT
CORRECT INSTALLATION

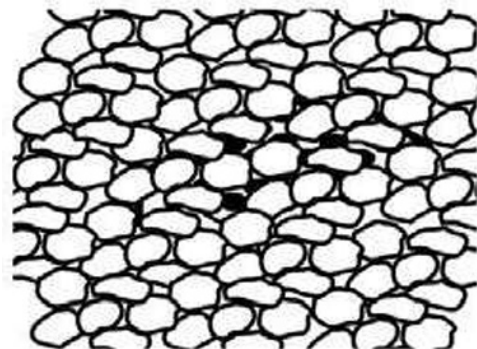

PILOT
INCORRECT INSTALLATION

CORRECT INSTALLATION

- Only Fire-Rated Media.
- Pan to hold Media.
- Proper venting and cavity.

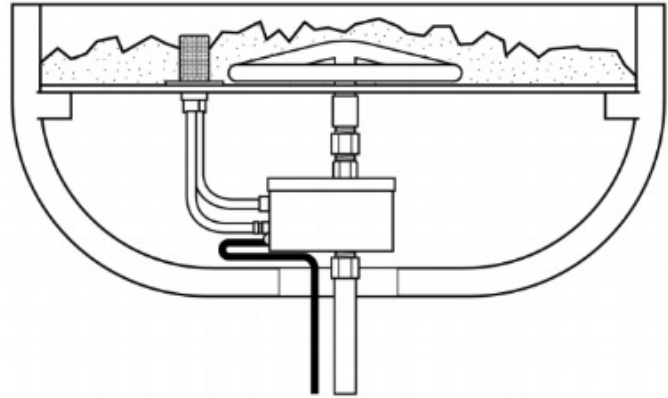

INCORRECT INSTALLATION

- No pan to hold Media.
- Improper venting.
- Covers Pilot Igniter..

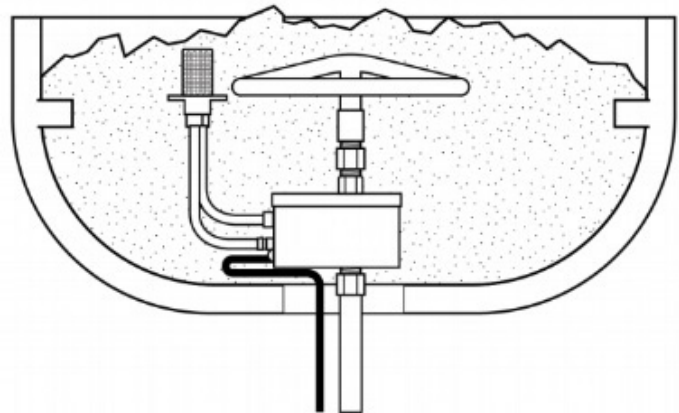

WARNING

Failure to position the parts in accordance with these diagrams or failure to use only parts specifically approved with this appliance may result in property damage or personal injury.

FLAT FIRE PAN

- Hidden Pan
- Great for Natural Stone
- Custom Sizing Available

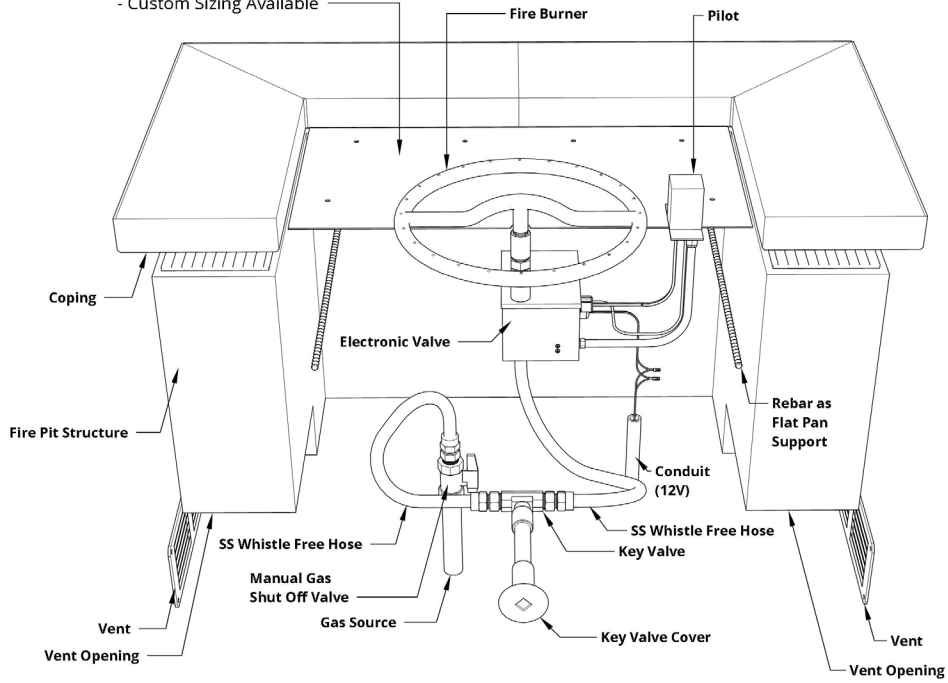

DROP-IN FIRE PAN

- Built in Support / 1" Flange
- Great for Flat Surfaces
- Custom Sizing Available

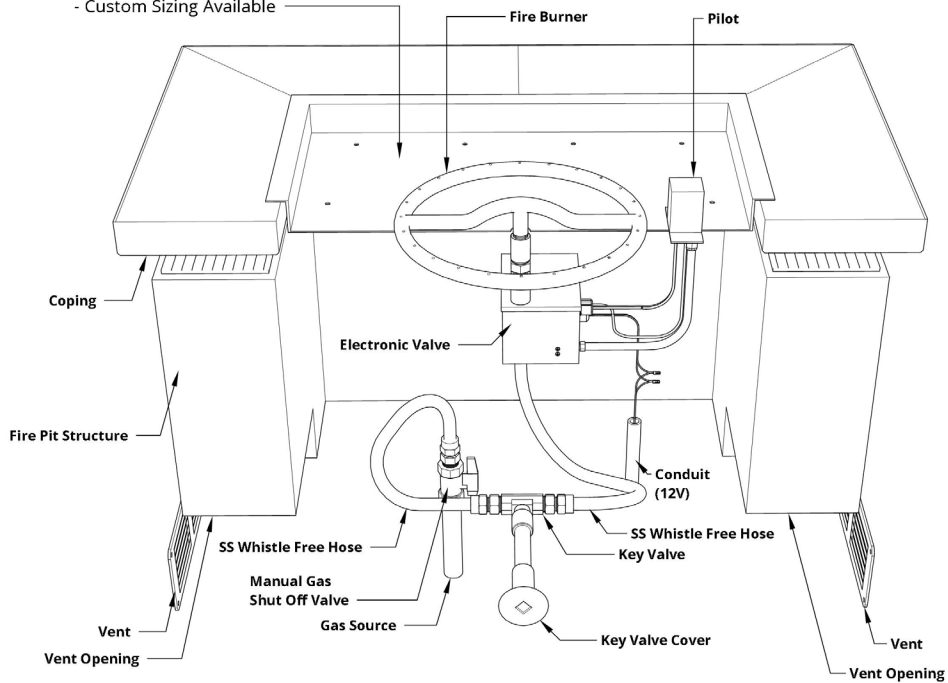

Your fire feature should include one of these methods for activating and deactivating it:

LIGHT SWITCH

- Simply flick the light switch to turn on or off the fire feature, you may leave the key valve in the open position since the electronic valve automatically opens and closes to allow gas flow.

DIAL TIMER

- Turn the dial timer knob clockwise to the desired run time and the feature will turn on.
- To shut off the fire feature turn the dial counter-clockwise to the OFF position.

POOL CONTROLLER

- Our Low Voltage Ignition Systems work with a variety of pool controller brands and models, please reference your pool controller manual for operation of fire features.
- You can activate multiple fire features at once using one button with the included low voltage transformer, or opt for individual buttons for each feature by getting additional transformers for multiple electronic fire features.

SMART HUB/HOME AUTOMATION

- Our Low Voltage Ignition Systems work with a variety of Home Automation Systems, please reference your Home Automation manual for operation of fire features.
- You can activate multiple fire features at once using one button with the included low voltage transformer, or opt for individual buttons for each feature by getting additional transformers for multiple electronic fire features.

STARTING UP YOUR ELECTRONIC IGNITION COMPONENT

- Start-up: A few “On/Off” cycles may be required in order to properly air within the gas lines after installation. The Fire Pit will lockout after 10 attempts to light the pilot - if this happens, power OFF then ON to restart.

SEQUENCE OF OPERATIONS

1. The hot wire igniter will glow red (meaning that it is powered) for 5 seconds before the pilot valve opens.
2. The hot wire igniter will only become powered for the initial 15 seconds of the 60-second pilot cycle. This sequence repeats up to 10 times (approx. 15 minutes) before going into lockout.
3. Pilot flame will ignite and warm the thermocouple, taking approximately 30 seconds to get hot. If it is not hot within 60 seconds, the system will shut down and you will restart from Step 1.
4. Once the thermocouple is hot, the main valve will open and allow the burner to ignite.
5. If the pilot flame is blown out at any point, the Electronic Ignition Components will shut down and will restart from Step 1.

IMPORTANT

- If power to the fire pit is turned off and immediately turned back on, the system will go into lockout mode. To reset, turn off the feature, wait 5 minutes, then turn on.
- To reset after lockout, power the unit down and restart after the 5 minute cool down period.
- Once the fire feature has been ignited DO NOT leave unattended.

FIRE PIT SHUT-DOWN

- Turn off the fire pit using your designated powering source - either remote control or wall switch.

NOTE: For Remote Control use, you must also turn off the power to the electrical outlet or gas to the fire feature in order to prevent an accidental start.

- Once the fire pit is cooled, you may put the appropriate cover over your feature for protection.



WARNING

OVERHEATING: The Fire Feature will automatically close the gas valve if temperatures exceed 175° F inside the valve box to prevent component damage. When the unit cools below 175° F it will automatically restart. To correct overheating, ensure that the enclosure has adequate ventilation.

HELPFUL TIPS FOR PROPER OPERATION

- Cross Ventilation is **REQUIRED!** A minimum of 1 square inch of ventilation is required for every 25,000 BTUs on each side of the installation.
- Media (Lava Rock or Fire Glass) must be a minimum of 1/4” and no larger than 3” in diameter.
For Natural Gas: You can use Fire Glass media or Lava Rock ranging from 1/4” to 3” in diameter.
For Liquid Propane: Avoid using glass pieces that are 1/2” in size or smaller. Opt for burning media between 1/2” and 3/4” - 1” in size, or larger.
- Media must not cover the pilot. The pilot needs air. Avoid packing media against the pilot.
- Media must be approved by the appliance manufacturer.
- A Heat Shield/Pan **MUST** be installed between the Burner and Electronic Ignition Valve.
- The Electronic Ignition Valve has a temperature safety shutoff at 175° F.
- Be sure the gas shut off valve is open.
- If using wire notes, be sure they are weather proof and use dielectric grease on the wires.
- The unit is water resistant, **NOT** water proof. **DO NOT PUT IN WATER OR SUBMERGE.**

LED DIAGNOSTIC CODES

OFF	No Power / Internal Fault
ON	Normal Operation
1 FLASH	Hot start, Thermocouple Hot At Power Up
2 FLASHES	Trial Lockout, Maximum Ignition Trials Exceeded Without Flame Detection
3 FLASHES	Flame Loss Lockout, Exceeded Maximum Ignition Losses of Flame After Confirming Burner is On
4 FLASHES	Flame Sense Fault
5 FLASHES	Valve Fault
Fast Flash	Safety Shutdown

CONTROL TIMING

Pre-Purge	3.25 seconds
HSI Warm Up	5 seconds
Trial for Ignition	20 seconds
Flame Failure Response	10 seconds Max
Inter-Purge	5 seconds
Flame Loss Recycles	15 seconds
Flame Loss Recycles Delay	None

WIRE GAUGE CHART

WIRE GAUGE CHART Use the **Wire Gauge Chart** to the corresponding distance to ensure optimal performance for your ignition system.

Electrical Wire	6AWG	8AWG	10AWG	12AWG
Distance	5 FT	5 FT	5 FT	5 FT
	10 FT	10 FT	10 FT	10 FT
	20 FT	20 FT	20 FT	20 FT
	30 FT	30 FT	30 FT	30 FT
	40 FT	40 FT	40 FT	
	50 FT	50 FT	50 FT	
	60 FT	60 FT		
	70 FT	70 FT		
	80 FT	80 FT		
	90 FT			
	100 FT			
	110 FT			

WIRING DIAGRAM

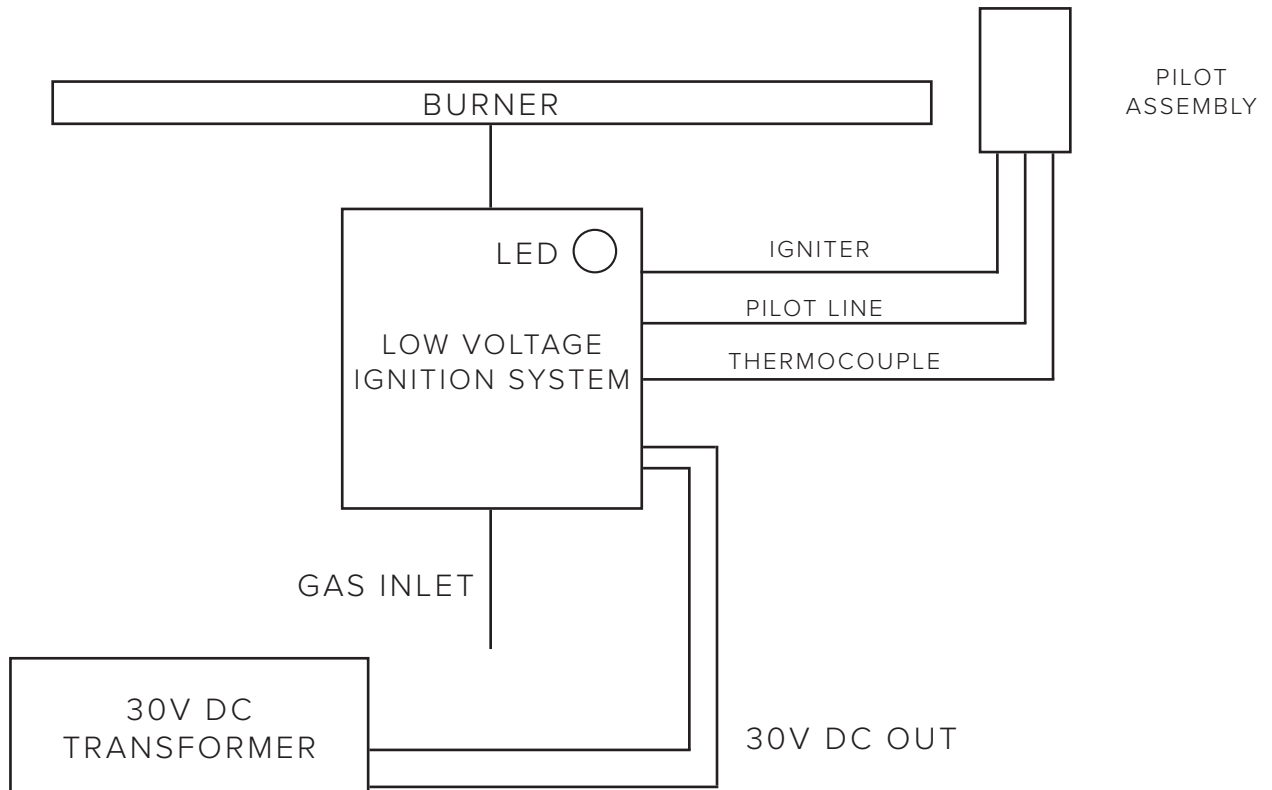

PROBLEM	SOLUTION
No Function / No LED Indication	1. Make sure transformer is powered. If so, replace transformer.
	2. Check wiring for continuity, replace if broken.
	3. Ensure wire is < 50 feet long and 12AWG minimum (smaller number is bigger wire). Replace with larger wire or shorten length. Replace with correct wiring if incorrect.
LED on, No Ignition	1. Replace Pilot Igniter
	2. Repair Pilot Igniter Wiring & Connector.
Igniter is On, but does not light. Control goes through all ignition attempts then enters 2 LED flash lockout	<p>Check to see if the pilot valve is open. If there is no gas flow:</p> <ol style="list-style-type: none"> 1. Check input gas pressure. Maximum pressure 1/2 PSI. Install regulator if higher. 2. Check voltage to pilot valve. Voltage should read >10.2VDC. Check "No or Low Voltage" above if less. 3. Check pilot coil for open circuit. Replace pilot valve if open.
	<p>Check to see if the pilot valve is open. If there is gas flow, but no ignition/low flame:</p> <ol style="list-style-type: none"> 1. Ensure air has been bled from gas line. 2. Consult The Outdoor Plus for minimum gas pressure. 3. If natural gas, ensure pilot jet is not for LP. 4. Check pilot injector for clogged jet. Clean or replace. 5. If pilot can be lit with a match, check igniter position and adjust, or check "No or Low Voltage" above.
The Pilot lights, but goes off at end of trial without main burner. 2 flash lockout after end of trials. Flame is not detected.	1. Check for clogged pilot or injector and clean.
	2. Check for correct pilot injector (LP or NG).
	3. Tighten Connection.
	4. Replace Thermocouple.
Units shut down after flame detected.	1. Maximum flame losses per heat cycle exceeded. Recycle power to reset.
	2. Ensure pilot flame is impinging on the thermocouple and is adequately sheltered from the wind. If impingement is consistent and no wind present, replace thermocouple.
	3. Turn power off for 10 seconds and back on. If persistent, replace control module.
	4. Turn power off for 10 seconds and back on. If persistent, check "No or Low Voltage" above. If voltage is okay, replace control module.
	5. Over Temperature - Ensure control compartment remains under 175° F. If continued operation above this temperature, life of product will be reduced.

THE ELECTRONIC IGNITION VALVE IS INSTALLED BUT WHEN TURNED ON NOTHING HAPPENS:

The most common cause is an electrical wiring or power issue. Inspect all electrical connections carefully to confirm all wires from the transformer to the fire feature are connected properly. If wiring is properly connected, disconnect the wires at the fire feature and use a multimeter to confirm a minimum of 30V DC when the fire feature is turned on. If there is not a minimum of 30V DC at the fire feature, conduct the same test at the transformer to determine if the transformer is truly producing a minimum of 30V DC. If you do have a minimum of 30V DC at the Fire Feature, contact The Outdoor Plus for further assistance.

THE ELECTRONIC IGNITION VALVE IS TURNED ON, THE IGNITER GLOWS ORANGE AND GAS CAN BE HEARD FLOWING, BUT DOES NOT IGNITE:

The two most common causes to this fault are; Air in the Gas Line or low Electrical Current to the fire feature.

Air in the Gas Line:

New gas line installations often have air trapped inside that must be removed or purged prior to installing the Electronic Ignition Valve. If the line has not been properly purged, it may take several cycles of turning the fire feature on and off before the all the air is purged from the gas line.

Understanding how the Electronic Ignition Valve operates will help you go through the purging process. When you turn on the Electronic Ignition Valve, the igniter will begin to glow, followed by the pilot gas valve opening 4 seconds later. During next 3 minutes the igniter will cycle on and off every 30 seconds while the pilot gas valve will remain on the entire time. Accordingly, if you are attempting to purge air from the gas line, engage the system and leave it on for approximately 3 minutes. Next turn it off and then back on. Let the system run for an additional 3 minutes. When purging air from a new gas line, you may need to cycle the power several times as described above before gas begins to flow. If at any point you smell gas and still don't have ignition, you should attempt to light the pilot flame with a hand held lighter. If ignition occurs when you light it by hand, please read the section titled Electrical Current.

Electrical Current:

If purging the gas line does not solve the problem, the ignition failure is most likely that the igniter is not getting hot enough to light the gas. The main reason an igniter will not reach full temperature is low amperage.

Electricians will commonly check the electrical power, note there are a minimum of 30V DC and think everything is fine electrically, so there must be a problem with the Electronic Ignition Valve.

The deficiency is not in the volts but rather the amps.

Amperage reaching the fire feature is dependent on the gauge wire used between the transformer and the fire feature. Our installation instructions require no less than 12 gauge wire up to 50 feet and 10 gauge for installs over 50 feet. Smaller wire size will often be the problem in ignition.

STEPS TO CHECK FOR SUFFICIENT AMPERAGE:

1. CAUTION: Turn off the gas supply before proceeding.
2. Utilizing clamp on ammeter, clamp the ammeter around one of the wires providing power to the Electronic Ignition Valve.
3. Turn on the Fire Feature.
4. Amperage should range between 1.4 to 1.6 amps initially. Four seconds after being turned on, the amperage will jump to approximately 2.0 amps.

If the amperage listed previously is not present AND the wire gauge used was less than listed above, change the wiring. Otherwise contact The Outdoor Plus for further assistance.

THE FIRE FEATURE WAS TURNED OFF, BUT SMALL FLAMES CAN STILL BE SEEN FLICKERING FROM THE FIRE FEATURE:

Turn the fire feature back on, let the main burner light and then turn it off again. You may need to do this several times. Small pieces of debris in the gas line may get caught in the main or pilot valve preventing it from completely closing. This is common in a new gas line. By cycling power you can often dislodge the debris. If cycling power does not rectify the problem, turn the gas off using the manual gas shutoff and contact The Outdoor Plus for further assistance.

CLEANING

- Inspect the appliance before initial use. Clean the appliance at least annually and have it inspected by a qualified field service person.
- Periodically examine the burner. If the burner is dirty, clean it with a soft wire brush. Remove any dirt or debris in this area. This will ensure long life and trouble-free operation.
- The easiest way to clean the fire pit is to let it cool completely off. Spray the enclosure off with water. Note: Do NOT spray water directly onto the burner and igniter and wipe clean with a dry cloth.
- When not in use and after cooling, cover your fire pit with a full length cover. The cover will help protect your fire pit from detrimental effects of weather and environmental pollutants (see your local The Outdoor Plus dealer for details).
- Before placing the cover on the fire pit, make sure the unit is shut off, that the gas lines are disconnected and that the unit has had sufficient time to cool.
- More frequent cleaning may be required as necessary. It is imperative the control compartment, burner and circulation air passageways of the appliance be kept clean and free.

MAINTENANCE

- Annually have a Licensed Gas Plumbing Technician check the hose connecting the propane gas cylinder to ensure it is not cracked or damaged in any way. All natural gas hook-ups should be serviced and inspected only by qualified installers only.
- Spiders and other insects can nest in the burners and block the gas and airflow to the burner ports. This creates a dangerous condition that can result in a fire from behind the valve panel. Inspect and clean the burners periodically.
- Any guard or other protective device removed for servicing the appliance must be replaced prior to operating the appliance.
- Inspect the fuel supply connection for signs of leakage (including the hose for propane models) before each use of the appliance.
- Do not repair or replace any part of your fire pit. Have a qualified technician perform all service. Any repairs made by a non-approved service technician will void your warranty.

STORAGE

- When your fire pit is not in use, turn off the gas at the source. To prolong your fire pit's lifespan, shield it from weather when idle. Let it cool before covering it. Warranty doesn't cover storage cover damage from heat or burns
- This appliance can be stored indoors only if it has been disconnected from its fuel supply.
- Store propane cylinders outdoors in a well ventilated area out of reach of children. Disconnected cylinders must have threaded valve plugs tightly installed and must not be stored in a building, garage, or any other enclosed area.

REMOVAL OF DEBRIS

- Do NOT perform the maintenance until surfaces of the fire feature are cool to the touch, The Outdoor Plus recommends leaving the fire pit off for at least 1 hour prior to servicing.
- Remove any debris on or around the fire feature such as spider webs, dirt, etc. by using a dry brush or compressed air.
- Pilot debris removal: Unscrew the pilot cover from the igniter. Use a dry brush or compressed air to clean out the pilot igniter. Place the pilot cover back on with the screw, after pilot igniter is cleaned.
- Cleaning soot off of the Thermocouple: Once every six months or as needed. Remove media around pilot, then the pilot hood lid by unscrewing the two screws. Clean thermocouple of any soot using soft brush. Be careful not to damage hot wire element. Place media back in, see Section 9 - Fire Media Usage.
- Visually inspect the pilot. The pilot flame should cover 3/8 inch to 1/2 inch of the thermocouple. Cleaning of the pilot orifice may be required by removing pilot hood screws, pilot hood, and removing the brass orifice.
- **WARNING:** Failure to position the parts in accordance with these diagrams or failure to use only parts specifically approved with this appliance may result in property damage or personal injury.

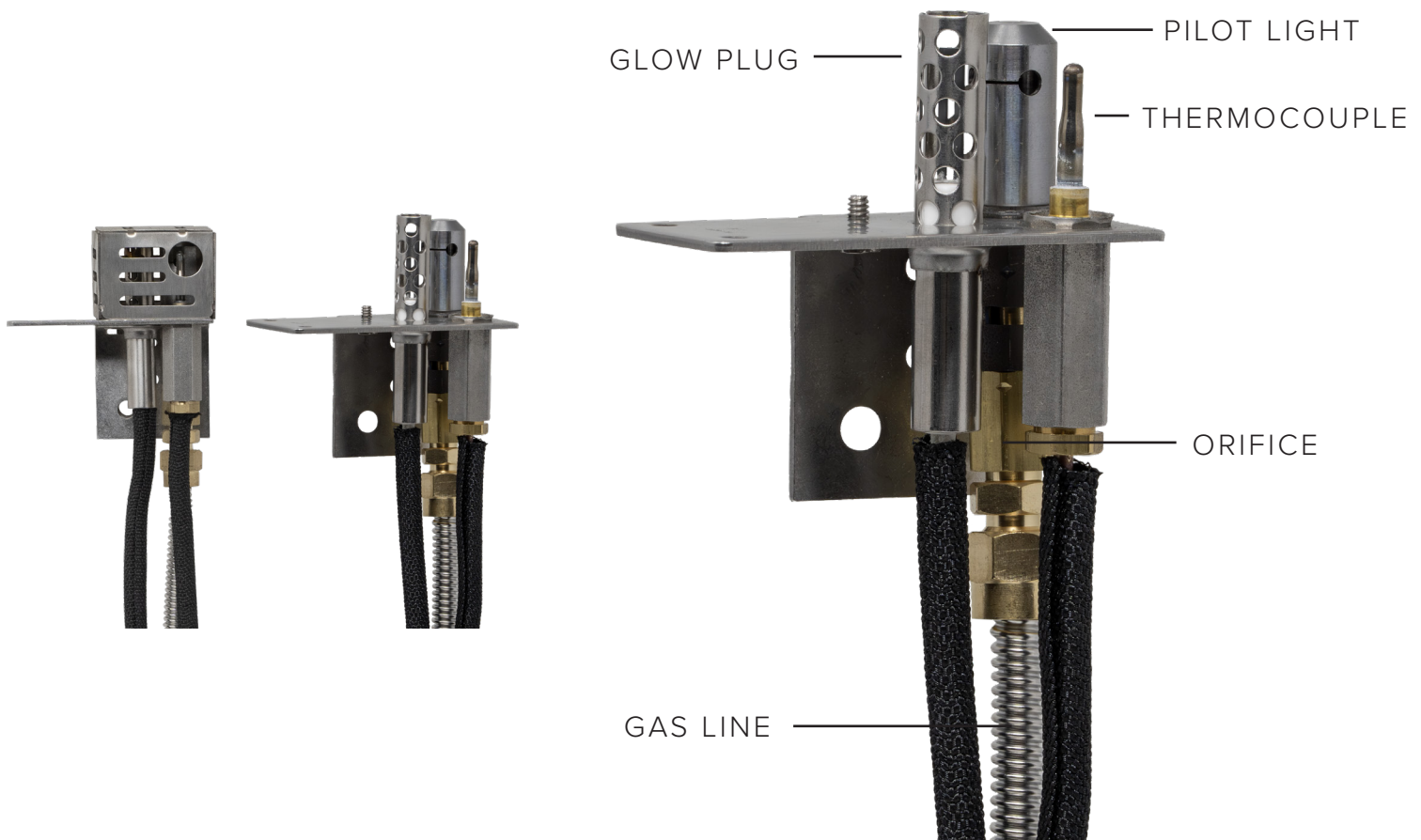



**30V DC
Transformer**
OPT - 12VDC



**Bluetooth
Receiver**
TOP - 500BLU



**Pilot Igniter
Cover**
TOP - PIC



**Pilot Igniter
Glow Plug**
TOP - PIGP



**24" Pilot Igniter
Assembly**
TOP-500PIR
**MINI & STANDARD
CAPACITY UNITS**



Pilot Orifice
TOP-PI31

CLEARANCE FROM COMBUSTIBLES

FLOORING

- All fire pits and fire features must be installed on non-combustible flooring. If the fire feature is installed on a combustible floor, such as wood decking or grass, a non-combustible floor paneling **MUST** be properly installed underneath. Do not install the Fire Feature on material that can obstruct ventilation such as grass, loose sand, and loose gravel.

INSTALLATION

- The Outdoor Plus recommends that our products be installed by professionals that are locally licensed by the authority having jurisdiction in gas piping.

SERVICE

- The Outdoor Plus recommends that our products be serviced by a professional certified in the US by the National Fireplace Institute (NFI) as NFI Gas Specialists.

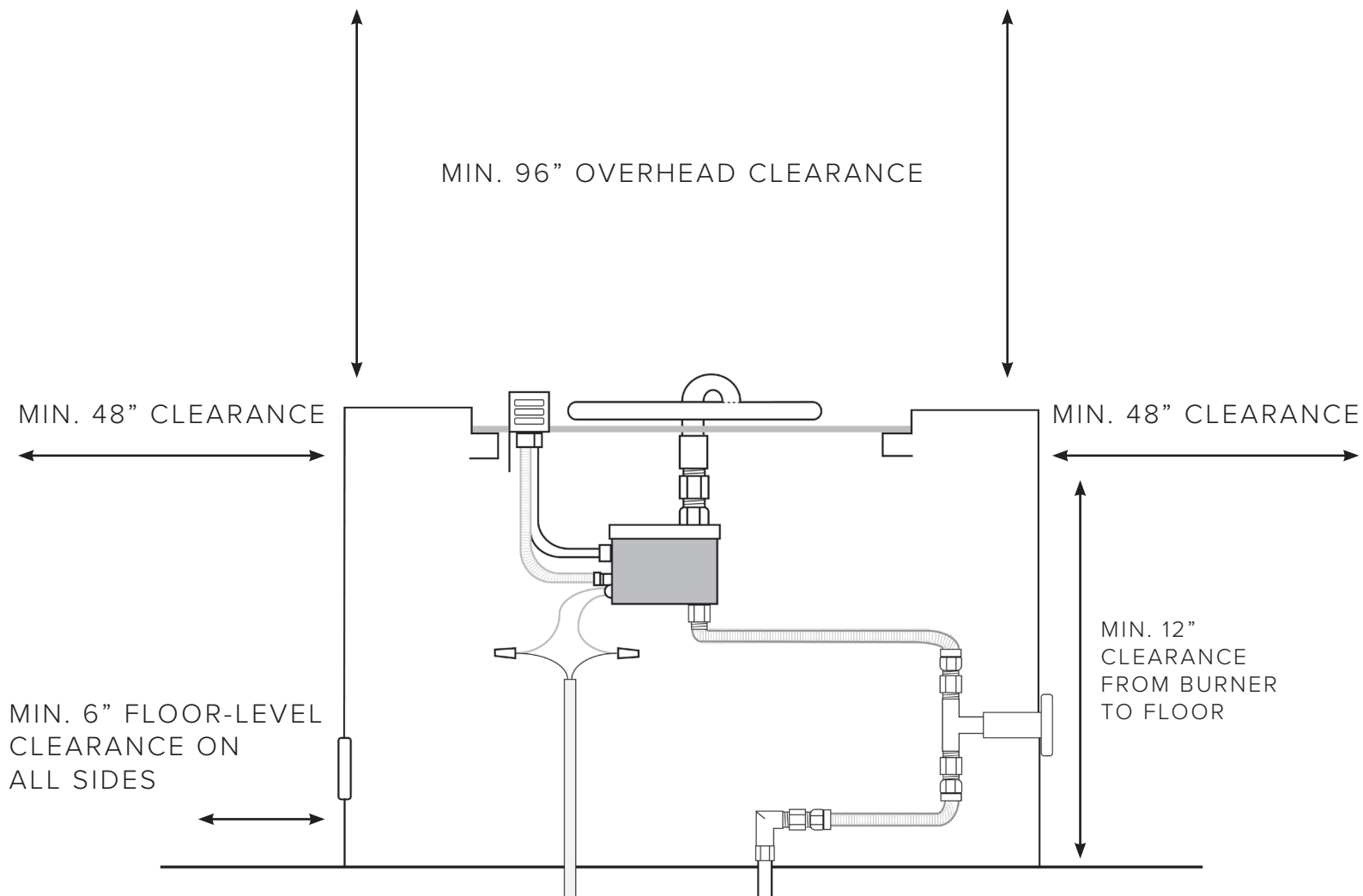

PRODUCT WARRANTY

The Outdoor Plus Company (TOP) warranties manufacturer defects that prevent safe and correct function as follows:

Warranty periods are as follows:

Electronics, Gas Valves, & Pilot Assembly

Commercial - 6 Months | Residential - 1 Year

Stainless Steel & Aluminum Pans

Commercial - 1 Year | Residential - 5 Years

Burner Ring & Burner Bars

Lifetime Warranty

Fire Pits/Bowls/Fireplaces/Paradise Falls/GFRC/ Powder Coat/Stainless Steel

1 Year Warranty

Self-Contained Units

Commercial - 6 Months | Residential - 1 Year

LED Lighting

Commercial - 6 Months | Residential - 1 Year

Torches

1 Year Warranty

Canvas Covers

1 Year Warranty

Stainless Steel Covers

1 Year Warranty

Wind Guards

1 Year Warranty - **Does Not Cover Cracking**

Copper/Corten Steel Products

Natural Weathering is not warrantied

Electrodes & Spark Igniters

Not Warrantied (due to lifespan)

Ready-To-Finish Products

Not Warrantied (due to the unfinished nature of the product)

Custom Products

Not Warrantied

Ornaments & Media

Not Warrantied (due to direct heat)

Product Return Policy

No returns on made-to-order goods.

No returns on custom features. NO EXCEPTIONS.

If a product is delivered incorrectly, it is the recipients responsibility to notify TOP within 48 hours.

TOP is not responsible for incorrect or damaged packages and shipments 48 hours after they have been received.

Product Testing Program

If you believe a unit or component you received is defective, The Outdoor Plus will gladly test any component at TOP's facility. TOP will cover shipping back to you.

Defective

If a product is found to be defective, The Outdoor Plus will repair or replace the item at their discretion. TOP will absorb all costs of outgoing freight and replacement costs if product is in warranty.

Non-Defective

If the product is found to be non-defective it will be returned to the customer - no credit will be given.

TOP Error

If a return is needed due to a mistake on TOP's part, we will issue an RMA and Return Services Label. When products are received at TOP, credit will be issued for the products and the outgoing freight on the original invoice.

Customer Error

If an RMA is asked for and covers current new products in the original package, we will authorize the return. The customer is responsible for the return shipping. When products are received we will issue credit for the original customer cost minus a 25% restocking charge.

Custom Orders DO NOT APPLY

Freight Policy

All orders will be shipped FOB Ontario, California, with a standard shipping carrier selected by TOP, unless customer specifically requests their own carrier and account. A Freight quote may be requested in advance. TOP works diligently with standard carriers to achieve the best discounts available.

PRODUCT WARRANTY



- This commences from the date of original sale/shipment from The Outdoor Plus.
- The warranty on parts and in-house labor will apply only to claims presented to us by TOP's original customer and is in lieu of all other warranties expressed or implied.
- The defective product must be sent back to TOP with a Return Merchandise Authorization (RMA) issued by TOP for that specific product which states the nature of the defect or warranty claim. The original purchase information will be required.
- Product to be returned should be packed carefully. The Outdoor Plus is not responsible for shipping damage on returned items.
- RMA's are only valid for 30 days which states the nature of the defect or warranty claim after the expiration date.
- The RMA number must be indicated on the outside of the return package and a copy of the RMA should be placed in the package with product.
- TOP is not responsible for damaged caused by overheating, modification, abuse, improper storage, installation, or maintenance.
- TOP is not responsible for surface level rust on stainless steel products.
- TOP is not responsible for the actions of third parties, including negligence of the installer.
- Any labor involving installation or maintenance with the unit is not covered.
- This warranty excludes claims for incidental or consequential damage and indirect collateral expenses arising from product defects or warranty recovery. Product manufactured by TOP including cLCus, UL, or CSA Certified models, cannot be altered or modified in any way.
- The Outdoor Plus strongly advises the use of a Stainless Steel Cover or Canvas Cover to protect your Fire Pit or Bowl from harsh weather. Keeping your feature covered when not in use extends its lifespan. Remove the cover before operating to avoid voiding the warranty.
- The Outdoor Plus Company is not liable for damages caused by any third-party moving companies. Customers are advised to ensure their chosen movers are careful and insured.
- The Outdoor Plus is not liable for any damages or failures arising from the installation of our Ignitions on a third-party's product. All ignition types must be installed with The Outdoor Plus product.
- The Outdoor Plus is not liable for any damages or malfunctions resulting from the use of third-party products.



PROUDLY DESIGNED &
MADE IN THE **USA**

 **THE OUTDOOR PLUS**
USA MANUFACTURER OF FIRE & WATER PRODUCTS

701 S DUPONT AVE
ONTARIO, CA 91761
(909) 460 - 5579

theoutdoorplus.com

